

FLUENT CONVEYORS SPEED SWITCHES

/ Collaborate / Create / Convey



Fluent Conveyors offers speed switches installed quickly by using magnetic design to attach to the shaft. They reduce costly setup and installation by eliminating the need for drill and tap. The breakaway design minimizes damage from falling debris compared to rigid design. The speed switches nylon housing is rugged and will perform well in harsh environments. Added benefit of LED illumination allows for visual monitoring.

STANDARD HOUSING CONFIGURATION

LOW PROFILE HOUSE CONFIGURATION

2" MAGNETIC COUPLER

1" MAGNETIC COUPLER

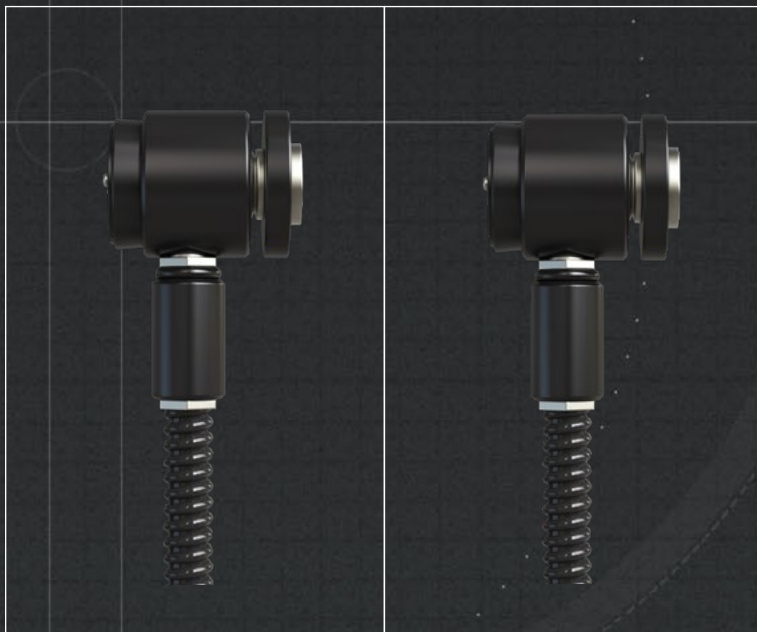

Low profile only available with small diameter magnetic connector.

For shaft sizes 1-¹⁵/₁₆" and Greater.

For shaft sizes 1-¹⁵/₁₆" and Smaller.

Technical Specifications & Speed Switches Modification Options

Please note not all Magnetic Speed Switches can be configured with each option.

Input Voltage

- 20-240V AC/DC

Pulses per Revolution

- 1 Pulse
- 2 Pulse
- 4 Pulse
- 12 Pulse
- Constant Signal Voltage

Wire Design

- 2 Wire (1-4 Pulse)
- 3 Wire (12 Pulse)

Speed Limits Max.

- 700 RPM
- 550 RPM
- 250 RPM

Magnetic Holding Force

- 80 lbs. (1" Base)
- 120 lbs. (2" Base)

Features

- Interface With Most PLCS
- Illuminated LED To Visually Inspect Proper Functioning
