

REPLACEMENT CONVEYOR MOTORS

/ Collaborate / Create / Convey

Fluent Conveyors uses Nord motors and drives as standard with our equipment. We do supply most manufacturers of drives and motors including Dodge, Sumitomo, Eurodrive and more so we can meet your needs. Our Replacement motors and drives can be had in many different configurations as well as washdown duty and explosion proof. These motor/reducer combos can be ordered as shaft mount or foot mount as well as regular duty, high efficiency, and premium efficiency/inverter duty.

PARALLEL SHAFT MOTORS/DRIVES

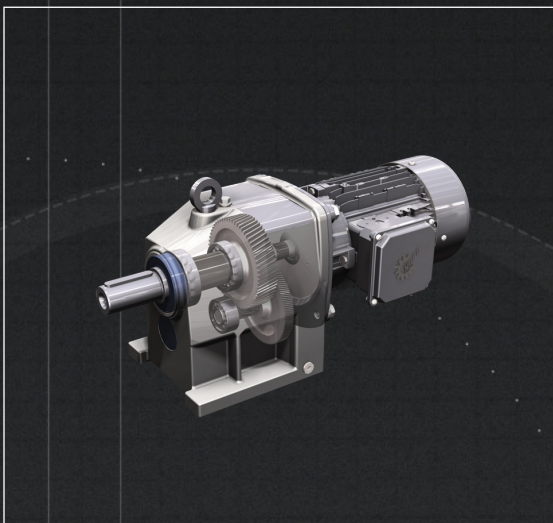

Parallel shaft drives are powerful and efficient drive designs. Fluent provides parallel shaft drives with torque ratings from 970lb-in up to 680,200lb-in. These drives are modular and can be mounted in many different positions so they can conform to fit your needs.

HELICAL BEVEL MOTORS/DRIVES

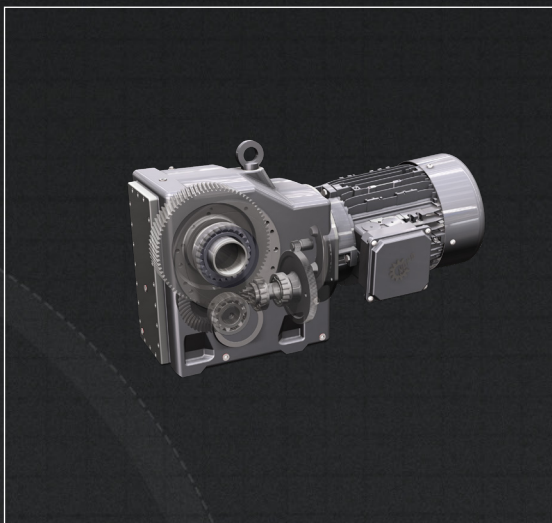

The helical bevel gearmotors can be had in single stage or two stage as well as cast steel housing or aluminum housing. These compact and powerful drive systems can come in various stages of carrier resistance and offer torques from 1,593lb-in to 442,500lb-in. The helical bevel gearmotors have many options including foot mounted, torque arm mounted, washdown duty and more.

HELICAL INLINE MOTORS/DRIVES

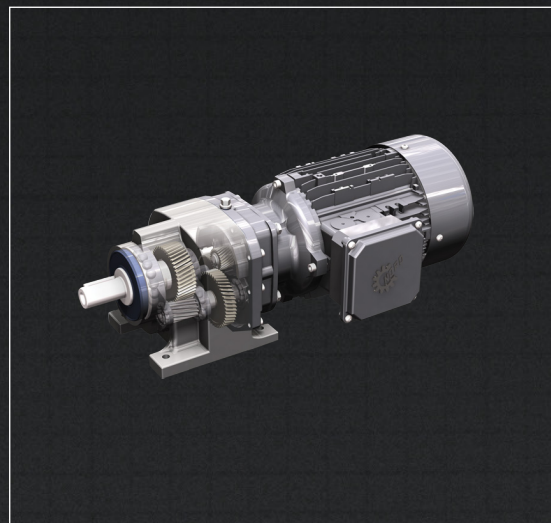

The helical inline motors have a compact design and torsionally rigid cast iron housing. They are hygienic and have good washdown functionality due to the smooth gear casing. These gearmotors are foot mounted and available in washdown duty as well as explosion proof. The helical gearmotors are available with torque ranging from 88lb-in to 230,000lb-in.

WORM GEAR MOTORS/DRIVES

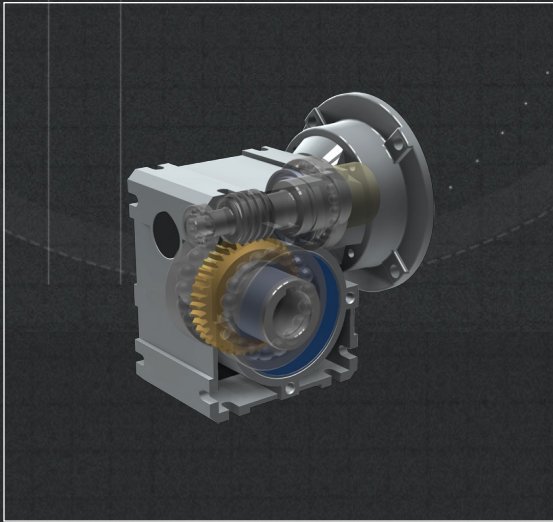

The worm gearmotors are a versatile and cost effective right angle solution. These drive units can be supplied with corrosion resistant coatings and in wash down duty. Our worm gear motors use a one piece housing which increases their operational torque and their axial and radial load capacity.

MOTOR BRAKES



Fluent offers motor brakes to match your drive unit. These can come installed on your drive unit or can be added afterwards. This removes slippage, roll back etc.

REPLACEMENT PARTS



Fluent conveyors offers replacement parts for gearmotors and drives. We offer everything from housing and seals to gears, roller bearings and shafts. Please contact your original OEM if you are looking for non Nord parts or components.

**We can use other motors, brands etc if needed. Our standard motors go up to 250 horse power.

Technical Specifications & Motor Modification Options

Please note not all motors/drives can be configured with each option.

Gearmotor Types

- Helical
- Helical Bevel
- Parallel Shaft
- Worm Gear
- Mechanical variable speed

Motor Types

- Asynchronous
- Synchronous
- 208/360 Volts
- 575 Volts

Power Options

- 230/460 Volts
- 332/575 Volts
- 208/360 Volts
- 575 Volts

Inverter Speed Range

- 5:1 Constant Torque Standard
- 10:1 Constant Torque
- 20:1 Constant Torque
- 1000:1 Constant Torque
- Line Powered Only

Mounting Options

- Shaft Mounted
- Torque Arm
- NEMA Footed
- IEC Footed

Gearmotor Options

- Washdown Duty
 - IP55, IP66
 - Explosion Proof
 - Sealed Terminal Box
 - Thermostat
 - Encoder
 - Additional offerings available upon request.
-