



REPLACEMENT HINGE BELT ROLLER CONVEYOR BELT

STEP A: BELT SPECS (SEE PAGE 4)

1	Pan Thickness	Inches	mm
2	Belt Width (Inside Sealing Wings)	Inches	mm
3	Belt Width (Overall Width)	Inches	mm
4	Roller Spacing	Inches	mm
5	Belt Length	Inches	mm

STEP B: ROLLER SPECS (SEE PAGE 5)

6	Roller Diameter	Inches	mm
7	Flange Roller Diameter (If Applicable)	Inches	mm
8	Roller Width	Inches	mm
9	Overall Roller Width (Includes Flanged Roller)	Inches	mm

STEP C: SIDE BAR SPECS (SEE PAGE 6)

10	Chain Pitch	Inches	mm
11	Side Bar Width	Inches	mm
12	Side Bar Thickness	Inches	mm
13	Single Or Double Row	Inches	mm

STEP D: SEALING WINGS SPECS (SEE PAGE 7)

14	Sealing Wing Height	Inches	mm
15	Sealing Wing Thickness	Inches	mm



STEP E: CLEAT SPECS (SEE PAGE 8)

16	Height Of Cleat (Angle Iron Shown)	Inches	mm
17	Thickness Of Cleat	Inches	mm
18	Total Length	Inches	mm
19	Offset From Sealing Wing	Inches	mm

STEP F: UNDERSIDE SUPPORT SPECS (SEE PAGE 9)

20	Support Type / Size (C-Channel Shown)	Inches	mm
21	Support Spacing (Every Other Pitch Shown)	Inches	mm
22	Support Length	Inches	mm

STEP G: BELT UNDERSIDE WEAR PADS SPECS (SEE PAGE 10)

23	Wear Pad Thickness	Inches	mm
24	Wear Pad Quantity (Two Per Pitch Shown)	Inches	mm
25	Wear Pad Spacing	Inches	mm
26	Wear Pad Location	Inches	mm
27	Wear Pad Size	Inches	mm



HINGE BELT COMPONENT OVERVIEW

STEP E

CLEAT SPECS NEEDED (IF APPLICABLE):

- 16: HEIGHT OF CLEAT (ANGLE IRON SHOWN)
- 17: THICKNESS OF CLEAT
- 18: TOTAL LENGTH
- 19: OFFSET FROM SEALING WING

STEP D

SEALING WINGS SPECS NEEDED (IF APPLICABLE):

- 14: SEALING WING HEIGHT
- 15: SEALING WING THICKNESS

STEP A

BELT SPECIFICATIONS NEEDED:

- 1: PAN THICKNESS
- 2: BELT WIDTH (INSIDE SEALING WINGS)
- 3: BELT WIDTH (OVERALL WIDTH)
- 4: ROLLER SPACING
- 5: BELT LENGTH

STEP G

BELT UNDERSIDE WEAR PADS SPECS NEEDED (IF APPLICABLE):

- 23: WEAR PAD THICKNESS
- 24: WEAR PAD QUANTITY (TWO PER PITCH SHOWN)
- 25: WEAR PAD SPACING
- 26: WEAR PAD LOCATION
- 27: WEAR PAD SIZE

STEP B

ROLLER SPECS NEEDED:

- 6: ROLLER DIAMETER
- 7: FLANGED ROLLER DIAMETER (IF APPLICABLE)
- 8: ROLLER WIDTH
- 9: OVERALL ROLLER WIDTH (INCLUDES FLANGED ROLLER)

STEP F

BELT UNDERSIDE SUPPORT SPECS NEEDED:

- 20: SUPPORT TYPE / SIZE (C-CHANNEL SHOWN)
- 21: SUPPORT SPACING (EVERY OTHER PITCH SHOWN)
- 22: SUPPORT LENGTH

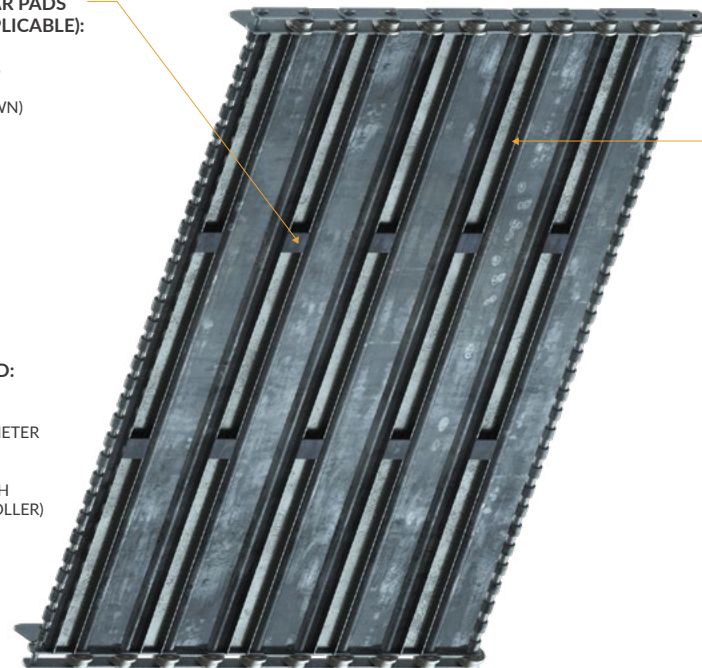

STEP C

SIDE BARS SPECS NEEDED:

- 10: CHAIN PITCH
- 11: SIDE BAR WIDTH
- 12: SIDE BAR THICKNESS
- 13: SINGLE OR DOUBLE ROW



STEP A: BELT SPECS

BELT SPECS NEEDED:

- 1: PAN THICKNESS
- 2: BELT WIDTH (INSIDE SEALING WINGS)
- 3: BELT WIDTH (OVERALL WIDTH)
- 4: ROLLER SPACING
- 5: BELT LENGTH

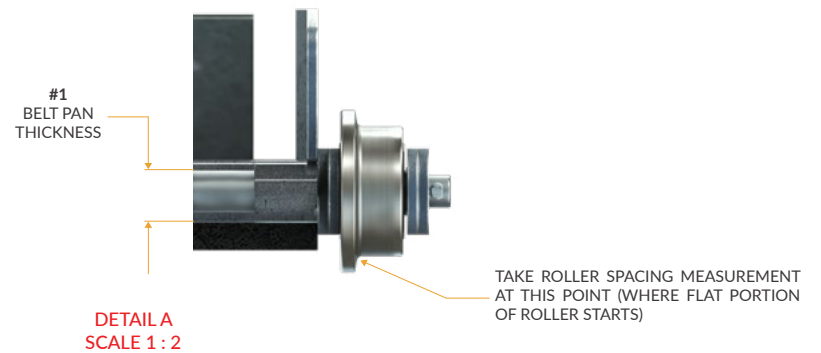
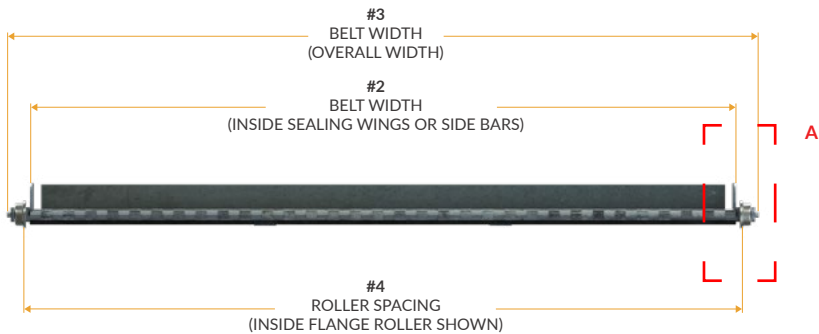
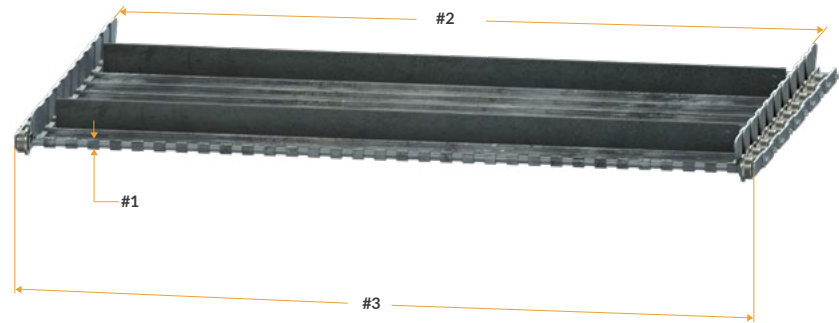



STEP B: ROLLER SPECS



ROLLER SPECS NEEDED:

- 6: ROLLER DIAMETER
- 7: FLANGED ROLLER DIAMETER (IF APPLICABLE)
- 8: ROLLER WIDTH
- 9: OVERALL ROLLER WIDTH (INCLUDES FLANGED ROLLER)

L B



C

DETAIL B
SCALE 1 : 2

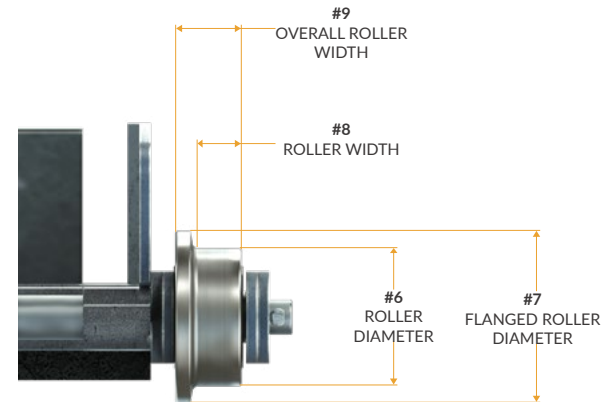
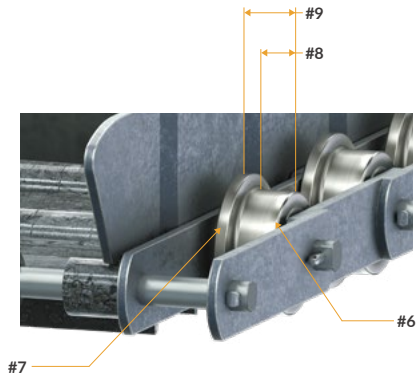

DETAIL C
SCALE 1 : 2



STEP C: SIDE BAR SPECS



D

SIDE BARS SPECS NEEDED:

- 10: CHAIN PITCH
- 11: SIDE BAR WIDTH
- 12: SIDE BAR THICKNESS
- 13: SINGLE OR DOUBLE CHAIN ROW



E



#10
CHAIN PITCH

#11
SIDE BAR
WIDTH

DETAIL D
SCALE 1 : 4

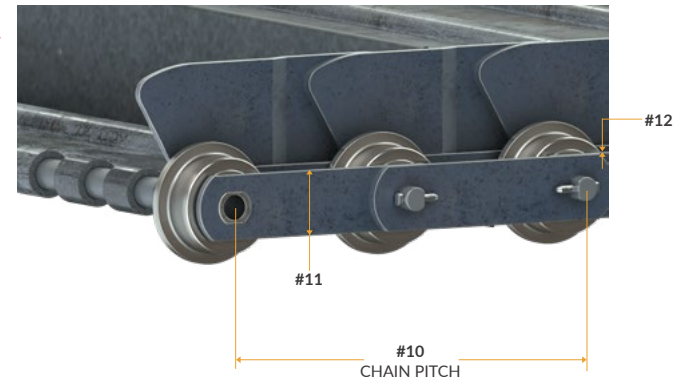

#11

#10
CHAIN PITCH

#12

*SEALING WINGS
ARE NOT COUNTED AS
DOUBLE CHAIN ROW

DETAIL E
SCALE 1 : 2

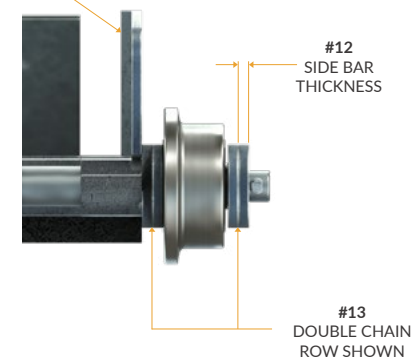

#12
SIDE BAR
THICKNESS

#13
DOUBLE CHAIN
ROW SHOWN



STEP D: SEALING WING SPECS

SEALING WINGS SPECS NEEDED
(IF APPLICABLE):

- 14: SEALING WING HEIGHT
- 15: SEALING WING THICKNESS

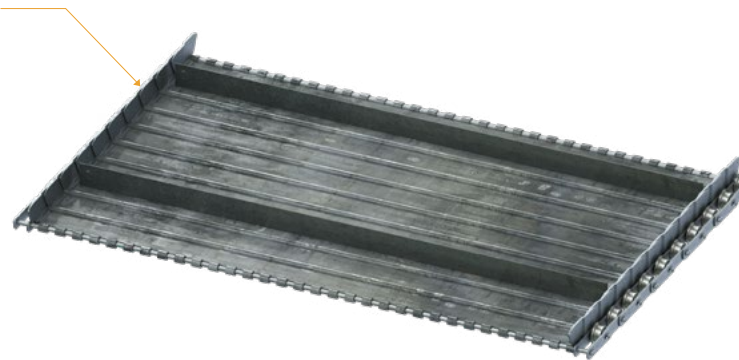

DETAIL F
SCALE 1 : 2



#14
SEALING WING HEIGHT
(MEASURED FROM
ROLLER CL)





STEP E: CLEAT SPECS

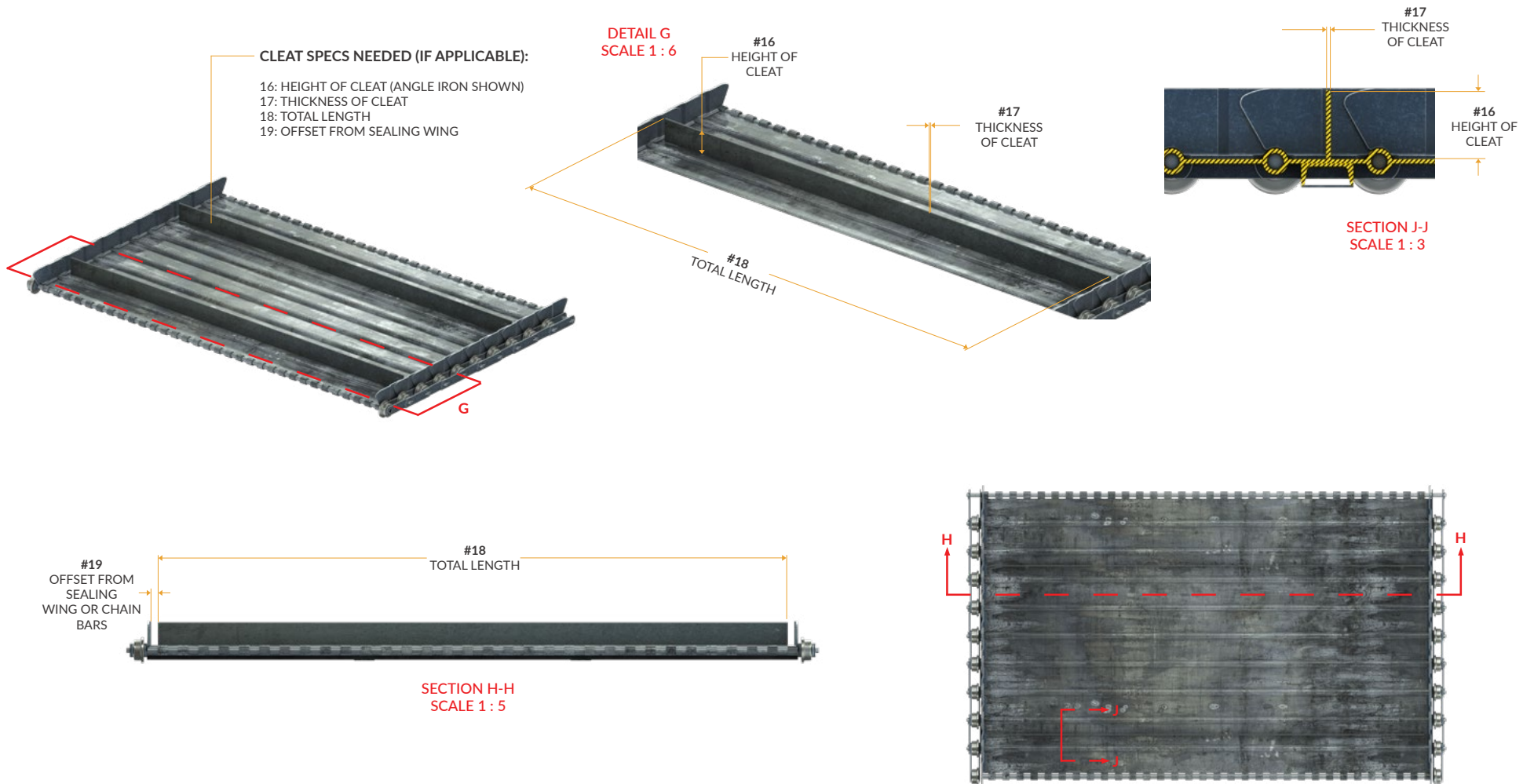



STEP F: BELT UNDERSIDE SUPPORT SPECS

BELT UNDERSIDE SUPPORT SPECS NEEDED:

- 20: SUPPORT TYPE / SIZE (C-CHANNEL SHOWN)
- 21: SUPPORT SPACING (EVERY OTHER PITCH SHOWN)
- 22: SUPPORT LENGTH

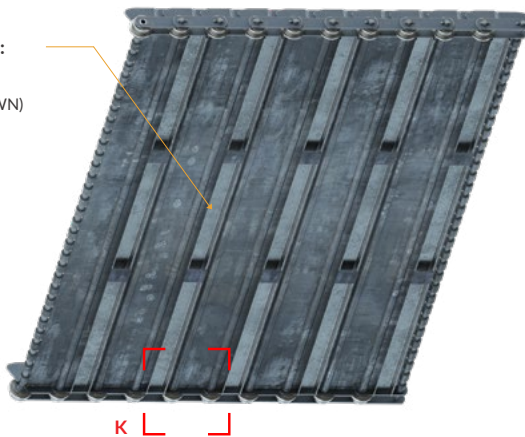

#20
C-CHANNEL SHOWN
(COULD BE ANGLE IRON
OR FLAT BAR)

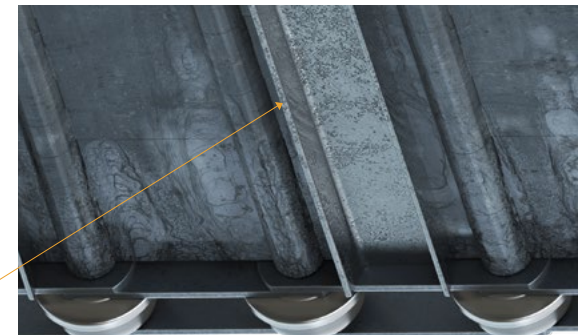

DETAIL K
SCALE 1 : 3

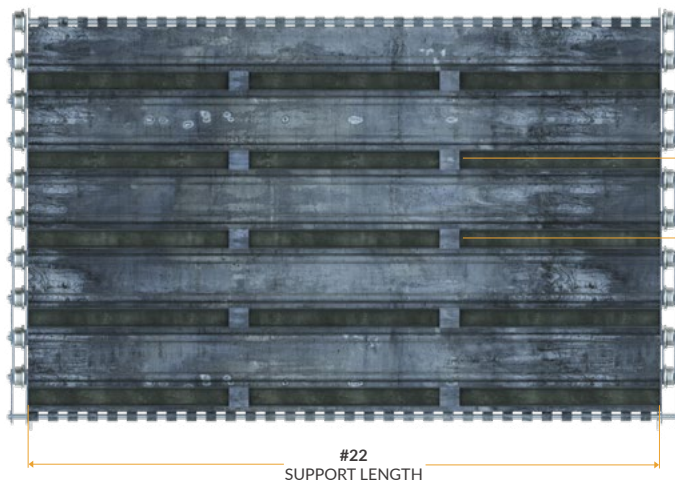

#21
SUPPORT SPACING
EVERY OTHER
CHAIN PITCH SHOWN

#22
SUPPORT LENGTH



STEP G: BELT UNDERSIDE WEAR PAD SPECS NEEDED (IF APPLICABLE)

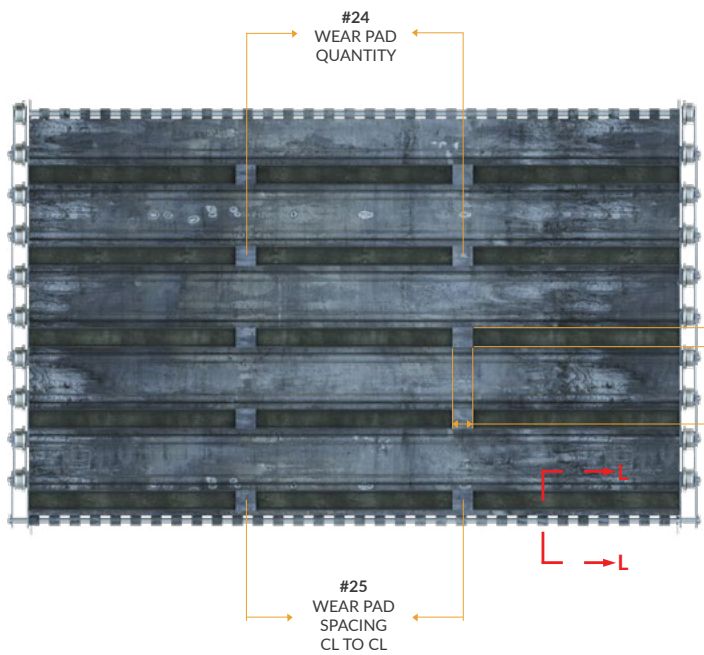

BELT UNDERSIDE SUPPORT SPECS NEEDED:

- 23: WEAR PAD THICKNESS
- 24: WEAR PAD QUANTITY (TWO PER PITCH SHOWN)
- 25: WEAR PAD SPACING
- 26: WEAR PAD LOCATION
- 27: WEAR PAD SIZE LENGTH & WIDTH

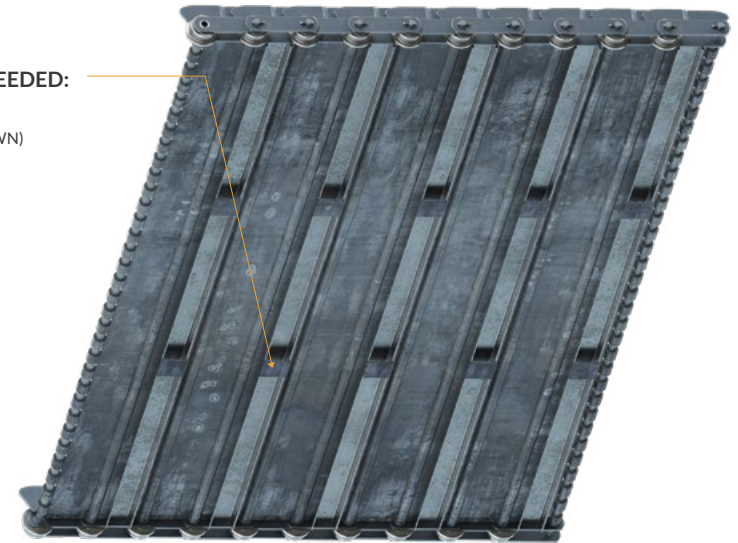

SECTION L-L
SCALE 1 : 3

