

# REPLACEMENT CONVEYOR BEARINGS

/ Collaborate / Create / Convey



Fluent Conveyors offers replacement bearings of all types for conveyors. We offer both roller and ball bearing inserts with stainless and ceramic balls in cast, stainless, corrosion resistant and composite bearing housings. We can supply bearing for your needs that range from light duty to heavy duty, as well as high temp and washdown duty. Fluent Conveyors has premium quality bearings for your conveying needs.

## PILLOW BLOCK BEARINGS

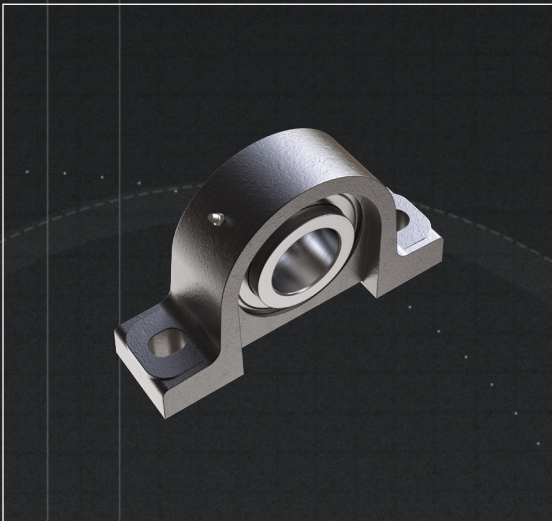

Standard cast or machined pillow block housings and light to heavy duty inserts to meet your strength requirements. Offered as standard, corrosion resistant, or high heat with roller, or ball bearings. Standard, High and Low heights with set screw bore lock and eccentric locking collar options.

## FOUR BOLT FLANGE BEARINGS

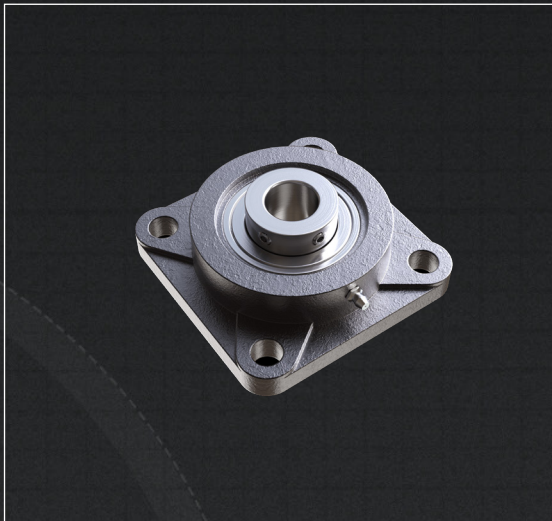

Four bolt flange bearing housings are offered in standard or corrosion resistant materials/paints with light to heavy duty bearing inserts to meet your strength requirements. These bearings can be had with standard seals or high heat and with roller, or ball bearings as well as chrome plated or stainless steel. Four bolt flange bearings are available with standard set screw bore or eccentric locking collars.

## TWO BOLT FLANGE BEARINGS

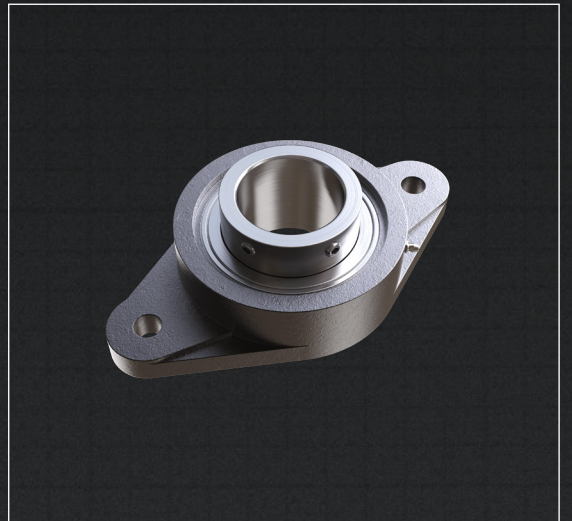

Two bolt flange bearing housings are offered in standard or corrosion resistant materials/paints with light to heavy duty bearing inserts to meet your strength requirements. These bearings can be had with standard seals or high heat and with roller, or ball bearings as well as chrome plated or stainless steel. Two bolt flange bearings are available with standard set screw bore or eccentric locking collars.

## TAKEUP BEARINGS

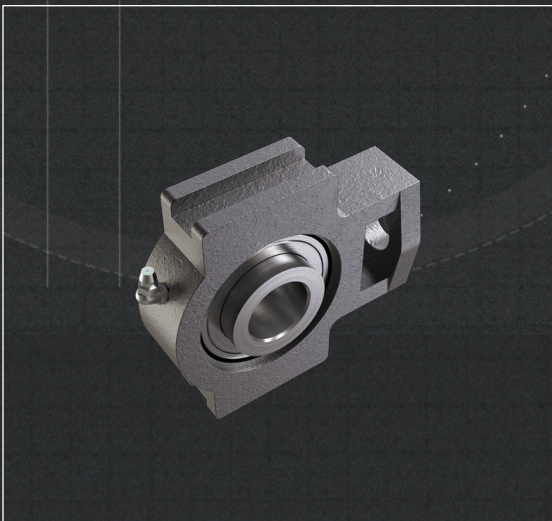

Fluent Conveyors offers take up bearings in both narrow and wide slot format and for light to heavy duty use. These can be furnished as standard cast housing or entirely stainless steel or composite. The takeup bearing inserts are available with high temp seals and all stainless inserts or ceramic for wet environments.

## 3 BOLT FLANGE BRACKET BEARINGS

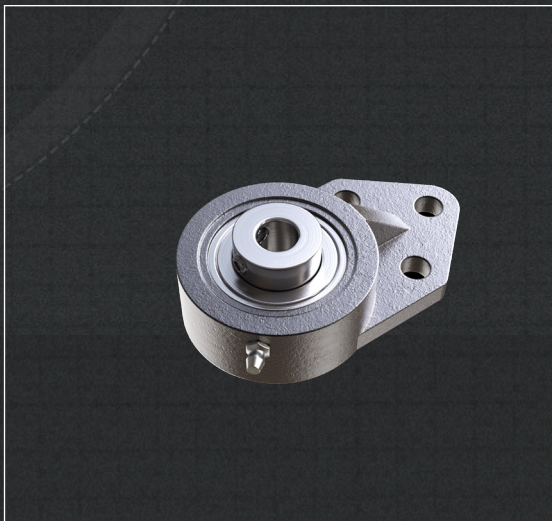

Fluent Conveyors has both standard duty and corrosion resistant options for 3 bolt flange bracket bearings. These are available with standard cast or all stainless steel bearing housings and standard or stainless steel bearing inserts.

## CUSTOM BEARINGS

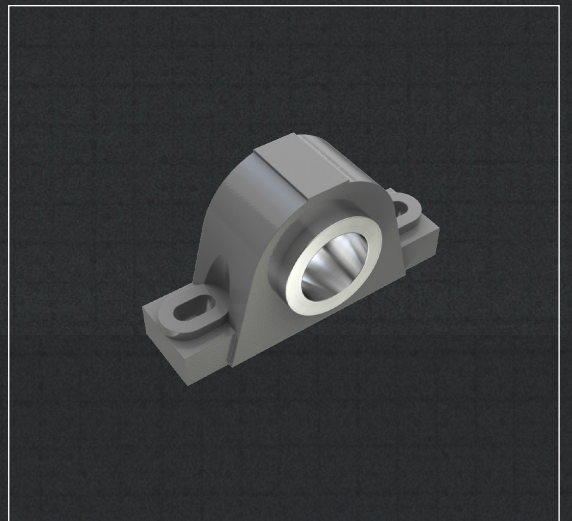

Fluent Conveyors also provides custom bearings to meet your needs. Whether it is high temperature, unusual dimensions, or under water we have the bearing and housing that you need.

\*\*Please note we offer more bearing types than shown here. Contact Fluent Conveyors if you need something else.

# Technical Specifications & Bearing Modification Options

Please note not all bearings can be configured with each option.

---

## Bearing Options

- Pillow Block
  - 4 Bolt Flange
  - 2 Bolt Flange
  - 3 Bolt Flange Bracket
  - Tapped Base Pillow Block
  - Hanger Unit
  - Take up unit
  - 4 bolt piloted flange
  - 3 bolt flange
  - Custom
- 

## Bearing Duty

- Standard Duty
  - Medium Duty
  - Heavy Duty
- 

## Insert Types

- Ball Bearing
  - Roller Bearing
- 

## Insert Materials

- Standard steel inserts
  - Stainless steel inserts
  - Ceramic bearings
- 

## Seal Options

- B-type seal
  - L3-type seal
  - High heat seal
- 

## Bore Options

- Standard set screw bore
  - Eccentric locking collar bore
-